



ROYAL C CYKELPULLERT & ROYAL PULLERT

Design: SHL DESIGN

ROYAL C med mulighed for fastlåsning af cyklen
Pullert og cykelpullert kan skabe et sammenhængende udtryk



ROYAL C N

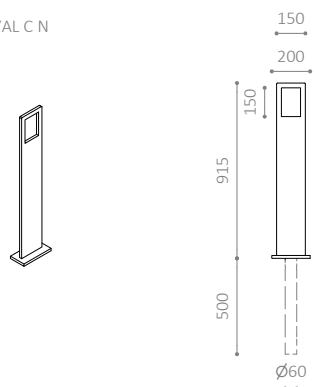

ROYAL N

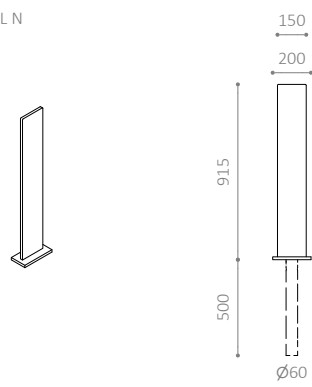

ROYAL C F

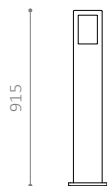
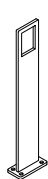

ROYAL F



ROYAL C TN

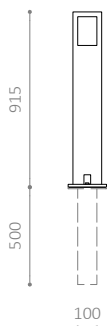

ROYAL TN

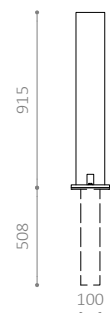
**ROYAL C CYKELPULLERT OG ROYAL PULLERT**

- Enkel og karakteristisk pullert
- ROYAL C med mulighed for fastlåsning af cyklen
- Pullert og cykelpullert kan skabe et sammenhængende udtryk
- Fås også i RAL-farver

MATERIALER:

- Varmgalvaniseret stål
- Fås også i pulverlakeret, varmgalvaniseret stål

MÅL:

Stander: 150 x 15 mm fladjern
Nedstøbningsdel: Ø60 mm

MONTERING:

- Fås til nedstøbning eller påboltning underlag, samt aftagelig
- Anbefalet afstand ved cykelparkering: c/c 1200 mm
- Anbefalet fundamentstørrelse: Ø300 x H600 mm
- Afstand fra terræn til overkant: 916 mm